

Rev.	Description	Date
A0	New release	2021.12.03

1. PHYSICAL CHARACTERISTICS (mm)

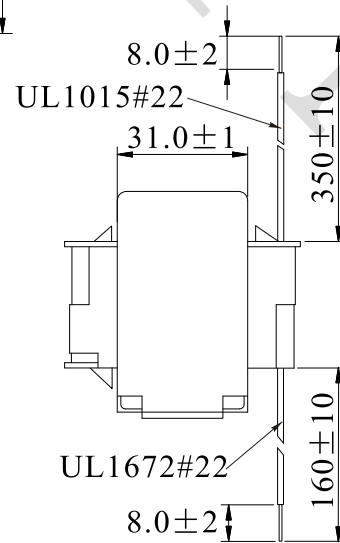

2. ELECTRONICAL SCHEMATIC

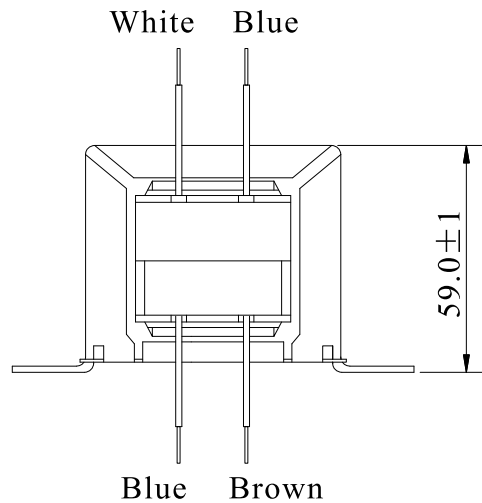
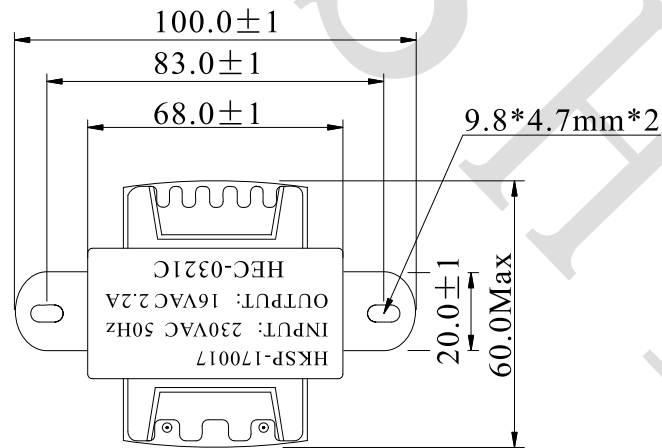
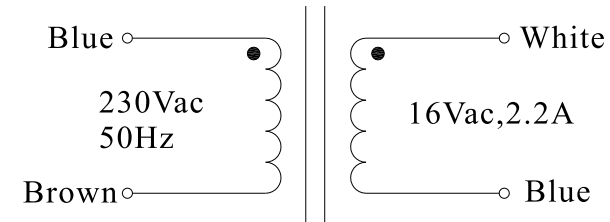

3. ELECTRONICAL SPECIFICATIONS

- Pri rated voltage: 230Vac, 50Hz
- Pri exciting current: 230Vac, 50Hz, 90mA Max
- Sec rated voltage: 16Vac ± 5%
- Sec rated current: 2.2A
- Sec no-load voltage: 19.5Vac Max
- Hi-Pot: 3.75KV, 50Hz, 1mA, 1min. Pri to Sec, Core
1.25KV, 50Hz, 1mA, 1min. Sec to Core
- Insulation test: 500Vdc, 100MΩ Min Pri to Sec, Core
- Storage temperature: -5°C to +60°C
- Operating temperature: -5°C to +85°C

NAME:	Transformer		
CUSTOMER P/N:	HKSP-170017	DATE:	2021-12-03
SHINHOM P/N:	LPT6628-16V-35W	REV: A0	PAGE
DRAWN BY	CHECKED BY	APPROVE BY	



SHINHOM

SHAANXISHINHOM ENTERPRISE CO LTD

The Document property belong to SHINHOM & is not allowed to be duplicated without authorization